

Paul Neuhaus

Paul Neuhaus GmbH
Olakenweg 36 · D-59457 Werl



+49(0)2922 9721 0

+49(0)2922 9721 9120

info@neuhaus-group.de

<https://scm.paul-neuhaus.de/public/conformity/>



D | Montageanleitung • GB | Fitting instruction

DE Dieses Produkt enthält eine Lichtquelle der Energieeffizienzklasse <E>.

GB This product contains a light source of energy efficiency class <E>.

FR Ce produit comprend une source de lumière de classe d'efficacité énergétique <E>.

ES Este producto contiene una fuente de luz de la clase de eficiencia energética <E>.

HR Ovaj proizvod sadrži izvor svjetlosti energetskeg razreda <E>.

HU Ez a termék <E> energiahatékonysági osztályba tartozó fényforrást tartalmaz.

IT Questo prodotto contiene una sorgente luminosa della classe di efficienza energetica <E>.

NL Dit product bevat een lichtbron van energie-efficiëntieklasse <E>.

838540

230V/50Hz~

1x LED-Board 24V DC/23W
nicht wechselbar / not changeable



2,4 GHz
10 dBm

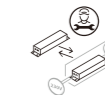

23 W
2.760 lm



30 W
1.550 lm



LED-Board



25.000 h



Tk 2.700-5.000 K



15.000 x



< 0,5 s



1x



AAA, 1,5V

6x



Inkl. IR-Fernbedienung
Incl. IR remote control





Die Leuchte darf nicht mit Feuchtigkeit in Berührung kommen!
Die Leuchte sollte nur mit Handschuhen berührt werden.

The luminaire must not come into contact with moisture!
The luminaire should only be touched with gloves.

1 | Montage / fitting

als Stehleuchte
as floor lamp

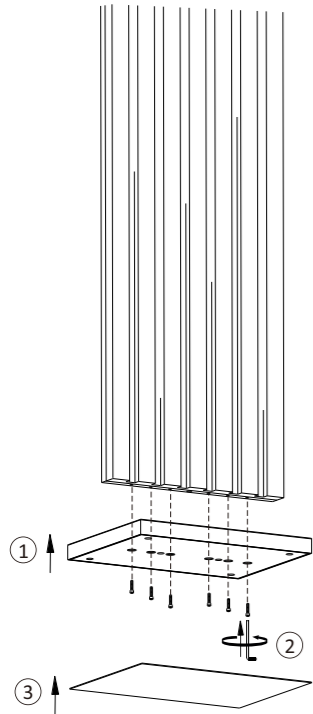

Teile dieser Leuchte bestehen aus Naturmaterial, somit ist jede Leuchte ein Unikat.
Beachten Sie, dass es zum Teil erhebliche Unterschiede in der Oberflächenbeschaffenheit und den Farben geben kann.

Parts of this luminaire are made of natural material, so each luminaire is unique.
Please note that there may be considerable differences in the surface finish and colors.

2 | Elektrischer Anschluss/ electrical connection

230Volt/50Hz-Anschluss
230 voltage/50 Hz connection

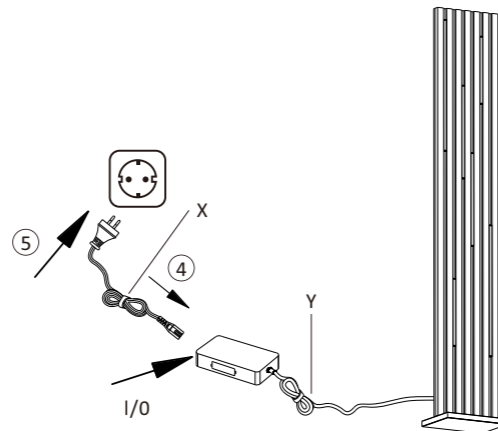

3 | Fernbedienung / remote control

Siehe Q-Fernbedienungsanleitung
See Q-remote control manual

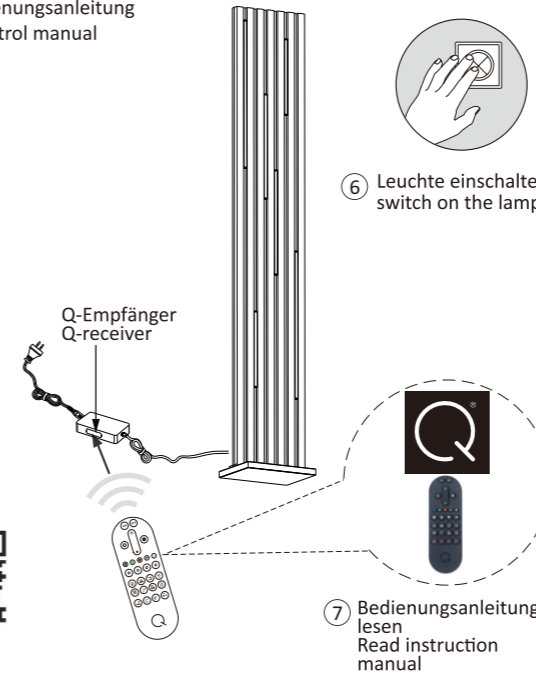

⑥ Leuchte einschalten
switch on the lamp

⑦ Bedienungsanleitung lesen
Read instruction manual



Reset

Zur Einbindung in ein ZigBee Netzwerk, stellen Sie die Leuchte auf Werkseinstellungen zurück.

To integrate the lamp into a ZigBee network, reset the lamp to the factory setting.

5x on/off

